

Mono 060 Trimless Concrete Type 1

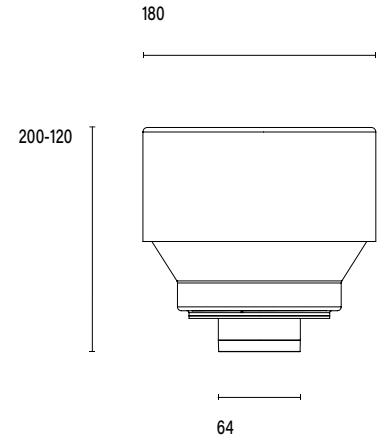

Model

Code	101 06 0031 --,---
Installation	Trimless Concrete - Indoor/ Outdoor
Finish	Structured White
Material	Marine Grade Aluminium

Technical Data

Power (Luminaire)	6.8W		
Power (System)	8w		
Voltage	240V-AC		
Current	180mA		
Optics	Rotationally Symmetrical Direct 25°/ 40°/ 60°		
Colour Temperature	2700K	3000K	4000K
Luminous Flux (lm)	576/ 626/ 624	642/ 680/ 672	612/ 614/ 652
TM30	Rf95 Rg103		
CRI	Ra97		
Lumen Maintenance	L90 B10 50000hrs		
Chromacity	<2 McAdam Step Ellipse		
Articulation	Fixed		
Ingress Protection	IP44		
Control Device	Control Excluded		
Class	III		



Mono 060 Trimless Concrete Type 1

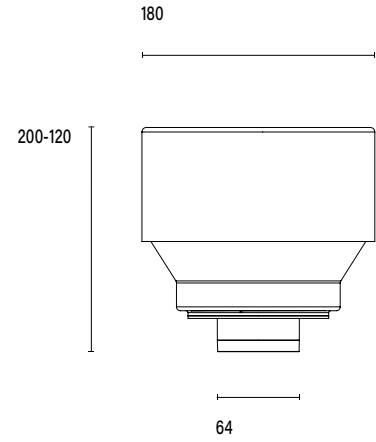

Model

Code	101 06 0031 --,---
Installation	Trimless Concrete - Indoor/ Outdoor
Finish	Structured White
Material	Marine Grade Aluminium

Technical Data

Power (Luminaire)	6W
Power (System)	7w
Voltage	240V-AC
Current	350mA
Optics	Rotationally Symmetrical Direct 25°/ 40°/ 60°
Colour Temperature	2700K - 1800K
TM30	Rf95 Rg103
CRI	Ra90
Lumen Maintenance	L90 B10 50000hrs
Chromacity	<2 McAdam Step Ellipse
Articulation	Fixed
Ingress Protection	IP44
Control Device	Control Excluded
Class	III



Mono 060 Trimless Concrete Type 1

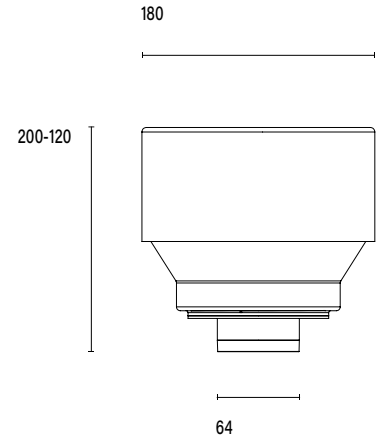

Model

Code	101 06 0031 --,---
Installation	Trimless Concrete - Indoor/ Outdoor
Finish	Structured White
Material	Marine Grade Aluminium

Technical Data

Power (Luminaire)	12W
Power (System)	14w
Voltage	240V-AC
Current	350mA
Optics	Rotationally Symmetrical Direct 25°/ 40°/ 60°
Colour Temperature	2700K 3000K 4000K
Luminous Flux (lm)	874/ 853/ 882 852/ 931/ 965 1044/ 1020/ 1049
TM30	Rf95 Rg103
CRI	Ra97
Lumen Maintenance	L90 B10 50000hrs
Chromaticity	<2 McAdam Step Ellipse
Articulation	Fixed
Ingress Protection	IP44
Control Device	Control Excluded
Class	III



Mono 060 Trimless Concrete Type 2

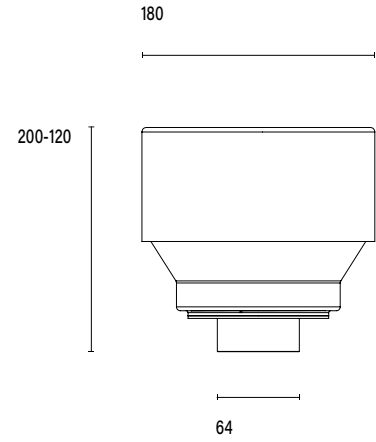
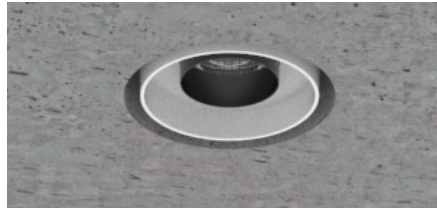

Model

Code	101 06 0032 --,---
Installation	Trimless Concrete - Indoor/ Outdoor
Finish	Structured White
Material	Marine Grade Aluminium

Technical Data

Power (Luminaire)	6.8W		
Power (System)	8w		
Voltage	240V-AC		
Current	180mA		
Optics	Rotationally Symmetrical Direct 25°/ 40°/ 60°		
Colour Temperature	2700K	3000K	4000K
Luminous Flux (lm)	576/ 626/ 624	642/ 680/ 672	612/ 614/ 652
TM30	Rf95 Rg103		
CRI	Ra97		
Lumen Maintenance	L90 B10 50000hrs		
Chromacity	<2 McAdam Step Ellipse		
Articulation	Fixed		
Ingress Protection	IP44		
Control Device	Control Excluded		
Class	III		



Mono 060 Trimless Concrete Type 2

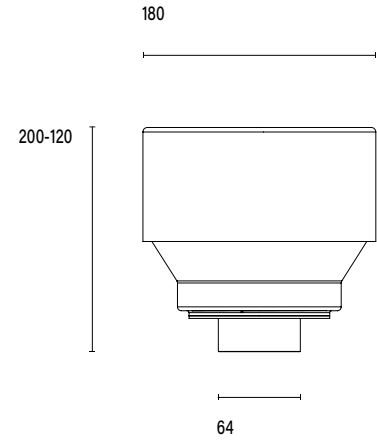
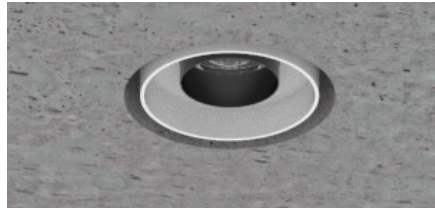

Model

Code	101 06 0032 --,---
Installation	Trimless Concrete - Indoor/ Outdoor
Finish	Structured White
Material	Marine Grade Aluminium

Technical Data

Power (Luminaire)	6W
Power (System)	7w
Voltage	240V-AC
Current	350mA
Optics	Rotationally Symmetrical Direct 25°/ 40°/ 60°
Colour Temperature	2700K - 1800K
TM30	Rf95 Rg103
CRI	Ra90
Lumen Maintenance	L90 B1 50000hrs
Chromacity	<2 McAdam Step Ellipse
Articulation	Fixed
Ingress Protection	IP44
Control Device	Control Excluded
Class	III



Mono 060 Trimless Concrete Type 2

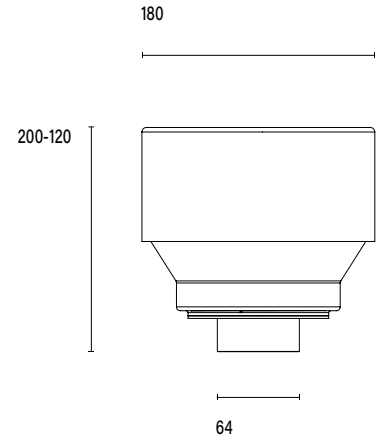
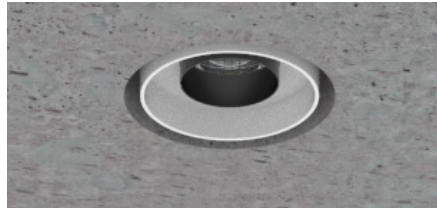

Model

Code	101 06 0032 --,---
Installation	Trimless Concrete - Indoor/ Outdoor
Finish	Structured White
Material	Marine Grade Aluminium

Technical Data

Power (Luminaire)	12W
Power (System)	14w
Voltage	240V-AC
Current	350mA
Optics	Rotationally Symmetrical Direct 25°/ 40°/ 60°
Colour Temperature	2700K 3000K 4000K
Luminous Flux (lm)	874/ 853/ 882 852/ 931/ 965 1044/ 1020/ 1049
TM30	Rf95 Rg103
CRI	Ra97
Lumen Maintenance	L90 B10 50000hrs
Chromaticity	<2 McAdam Step Ellipse
Articulation	Fixed
Ingress Protection	IP44
Control Device	Control Excluded
Class	III



Mono 060 Trimless Concrete Type 3

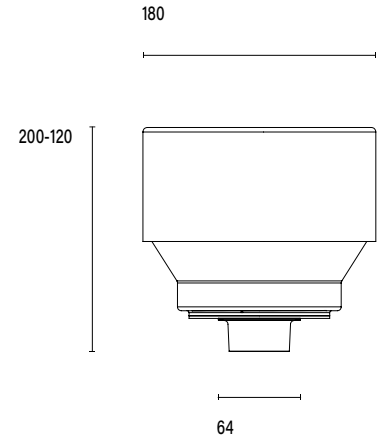
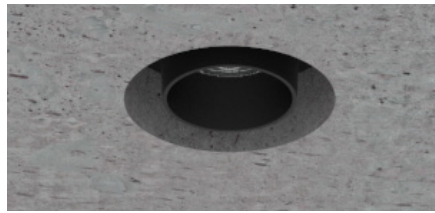
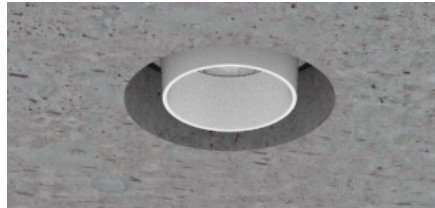

Model

Code	101 06 0033 --,---
Installation	Trimless Concrete - Indoor/ Outdoor
Finish	Structured White
Material	Marine Grade Aluminium

Technical Data

Power (Luminaire)	6.8W		
Power (System)	8w		
Voltage	240V-AC		
Current	180mA		
Optics	Rotationally Symmetrical Direct 25°/ 40°/ 60°		
Colour Temperature	2700K	3000K	4000K
Luminous Flux (lm)	576/ 626/ 624	642/ 680/ 672	612/ 614/ 652
TM30	Rf95 Rg103		
CRI	Ra97		
Lumen Maintenance	L90 B10 50000hrs		
Chromaticity	<2 McAdam Step Ellipse		
Articulation	Fixed		
Ingress Protection	IP44		
Control Device	Control Excluded		
Class	III		



Mono 060 Trimless Concrete Type 3

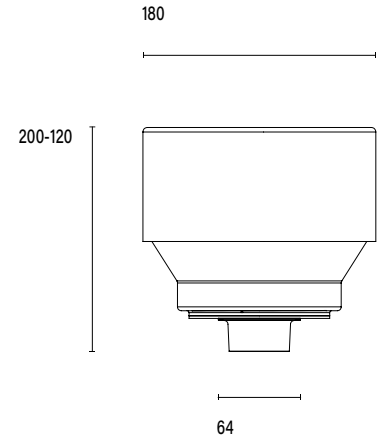
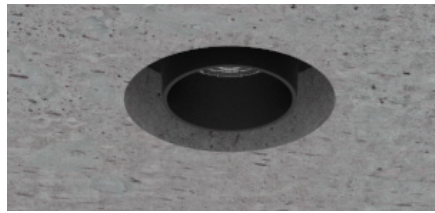
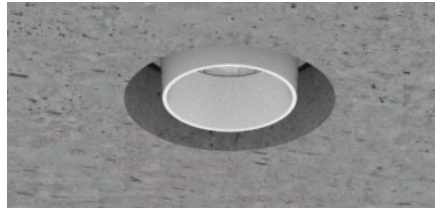

Model

Code	101 06 0033 --,---
Installation	Trimless Concrete - Indoor/ Outdoor
Finish	Structured White
Material	Marine Grade Aluminium

Technical Data

Power (Luminaire)	6W
Power (System)	7w
Voltage	240V-AC
Current	350mA
Optics	Rotationally Symmetrical Direct 25°/ 40°/ 60°
Colour Temperature	2700K - 1800K
TM30	Rf95 Rg103
CRI	Ra90
Lumen Maintenance	L90 B10 50000hrs
Chromacity	<2 McAdam Step Ellipse
Articulation	Fixed
Ingress Protection	IP44
Control Device	Control Excluded
Class	III



Mono 060 Trimless Concrete Type 3

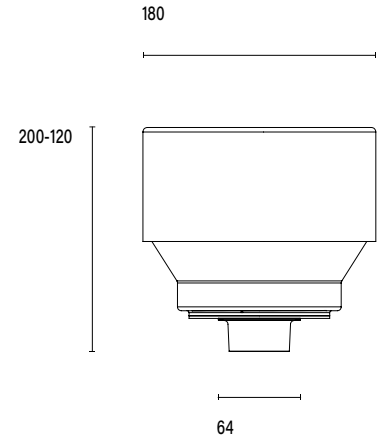
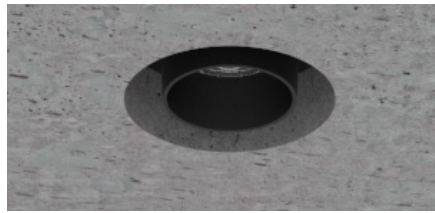
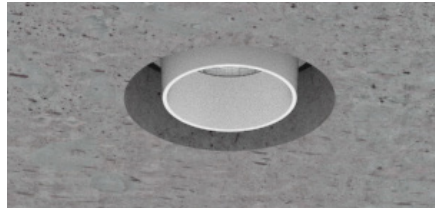

Model

Code	101 06 0033 --,---
Installation	Trimless Concrete - Indoor/ Outdoor
Finish	Structured White
Material	Marine Grade Aluminium

Technical Data

Power (Luminaire)	12W
Power (System)	14w
Voltage	240V-AC
Current	350mA
Optics	Rotationally Symmetrical Direct 25°/ 40°/ 60°
Colour Temperature	2700K 3000K 4000K
Luminous Flux (lm)	874/ 853/ 882 852/ 931/ 965 1044/ 1020/ 1049
TM30	Rf95 Rg103
CRI	Ra97
Lumen Maintenance	L90 B10 50000hrs
Chromaticity	<2 McAdam Step Ellipse
Articulation	Fixed
Ingress Protection	IP44
Control Device	Control Excluded
Class	III

