

Accent

100 10 0011 --,---

Power	8W
Voltage	240V-AC
Class	III
Ingress Protection	IP20
Cut-Out	Ø92 x 92mm Depth

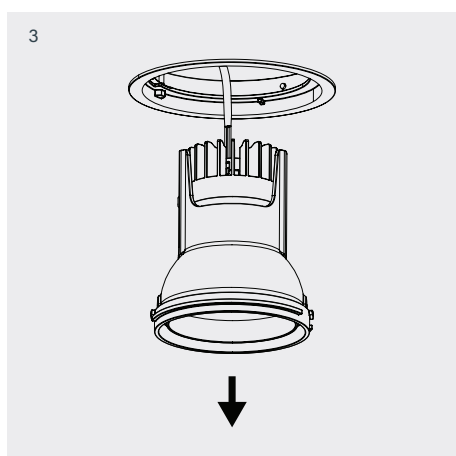
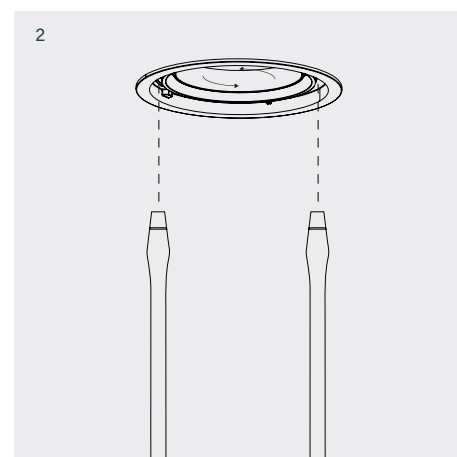
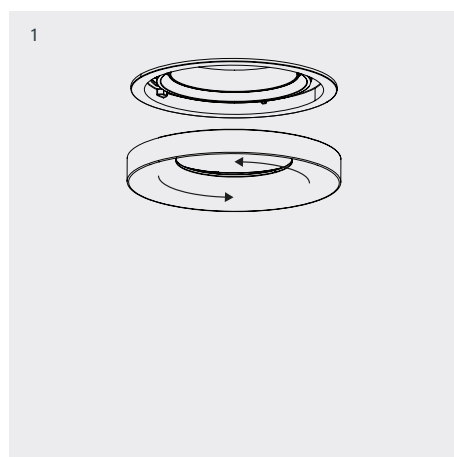
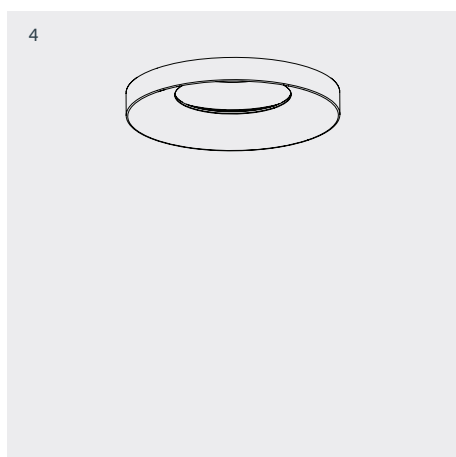
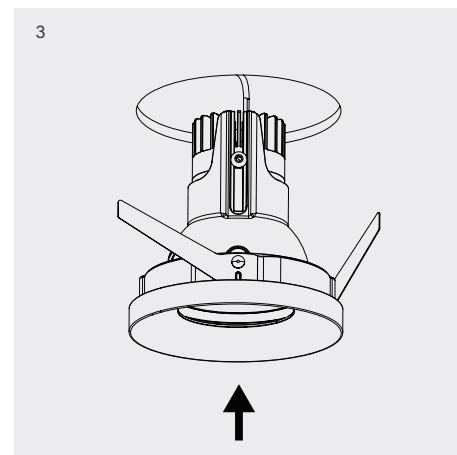
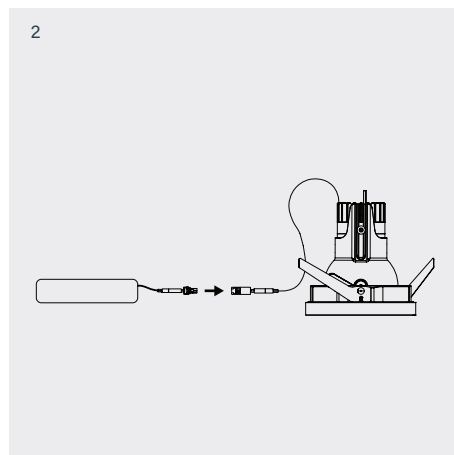
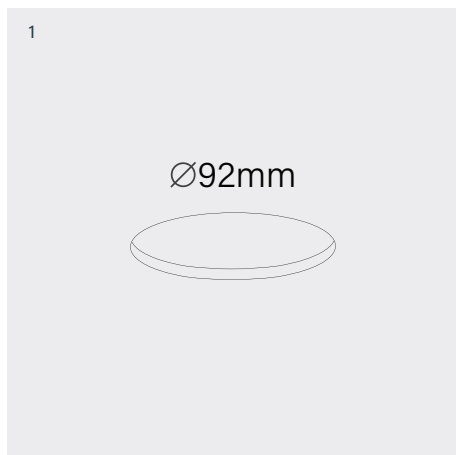

Installation

- 1 Cut 92mm diameter round aperture.
- 2 Plug driver into luminaire.
- 3-4 Fold back retention blades and insert luminaire into the aperture.

Maintenance

- 1 To access internal housing, remove facade by unscrewing anti-clockwise.
- 2 To remove the module housing, push back metal tabs using flathead screwdriver.
- 3 Twist the module housing, allowing it to drop out through tab slots.

Accent 100 Recessed Directional Type 1

100 10 0011 --,---

Power	14W
Voltage	240V-AC
Class	III
Ingress Protection	IP20
Cut-Out	Ø92 x 160mm Depth

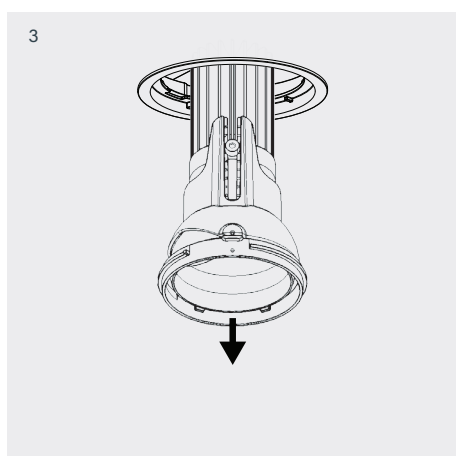
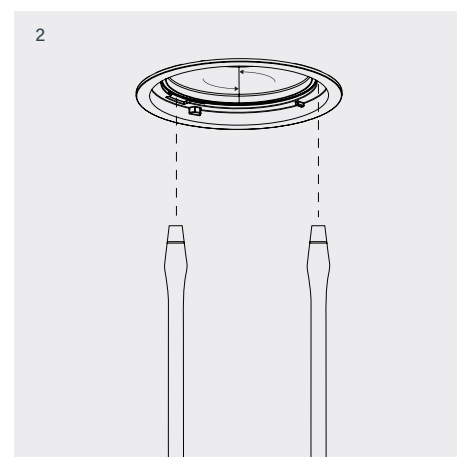
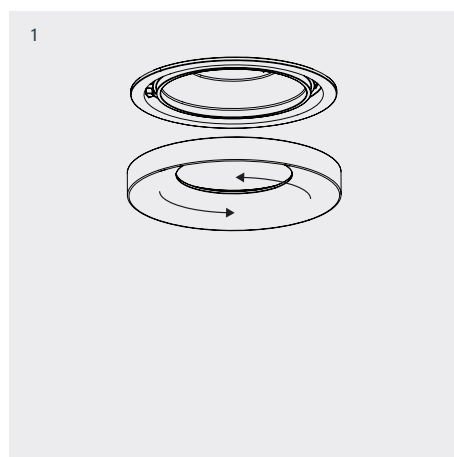
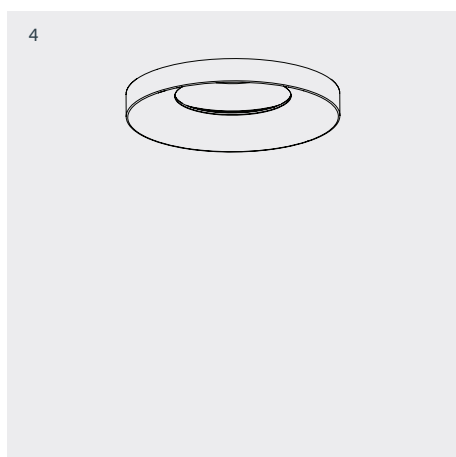
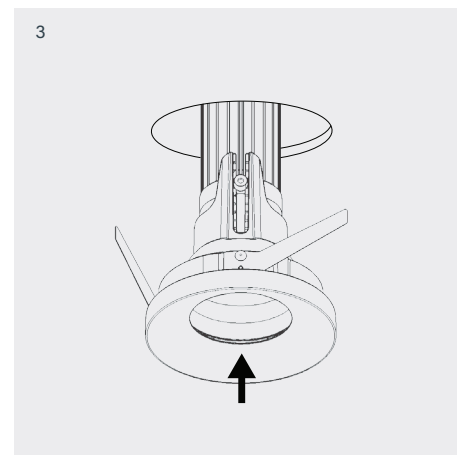
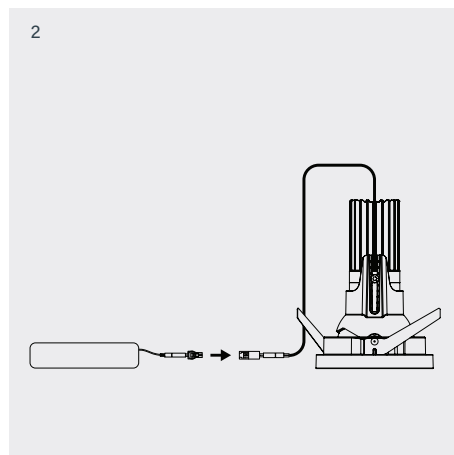
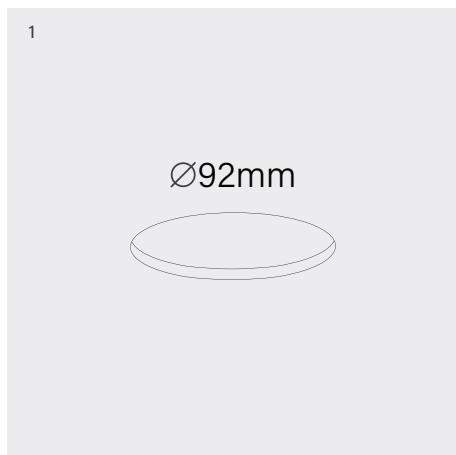

Installation

- 1 Cut 92mm diameter round aperture.
- 2 Plug driver into luminaire.
- 3-4 Fold back retention blades and insert luminaire into the aperture.

Maintenance

- 1 To access internal housing, remove facade by unscrewing anti-clockwise.
- 2 To remove the module housing, push back metal tabs using flathead screwdriver.
- 3 Twist the module housing, allowing it to drop out through tab slots.

Accent 100 Recessed Directional Type 2

100 10 0012 --,---

Power	8W
Voltage	240V-AC
Class	III
Ingress Protection	IP20
Cut-Out	Ø92 x 92mm Depth

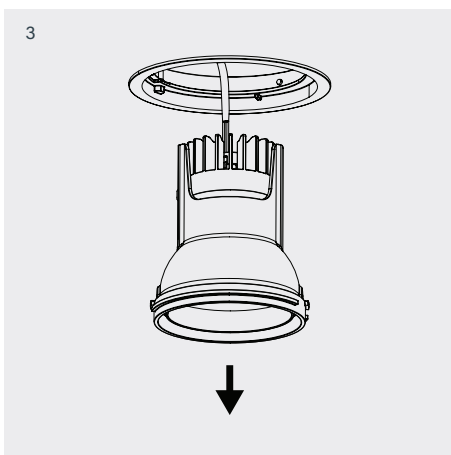
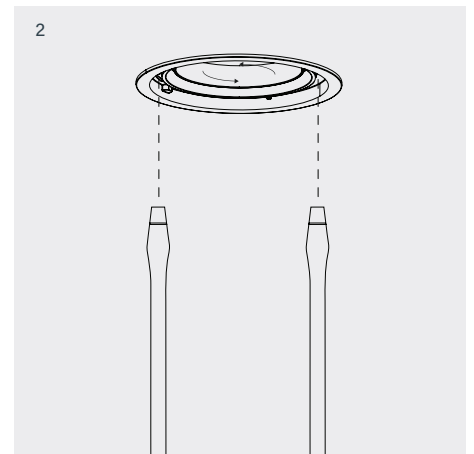
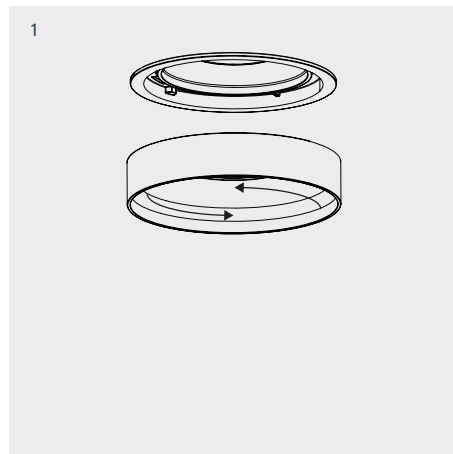
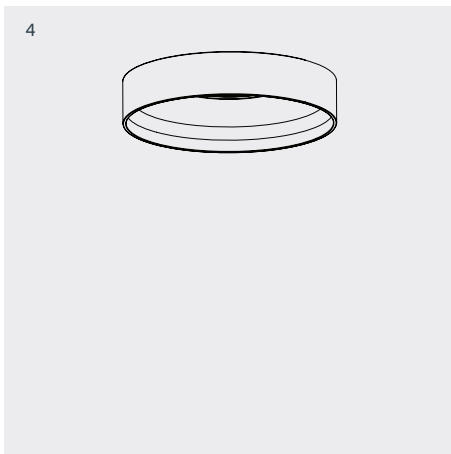
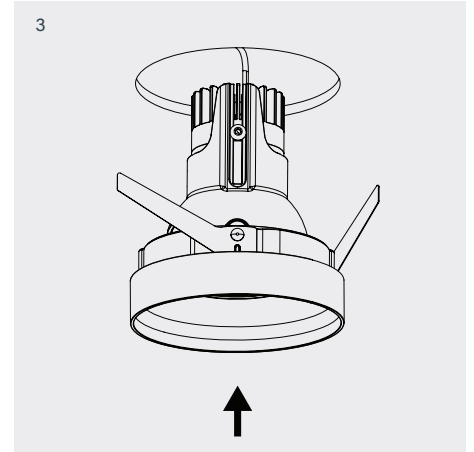
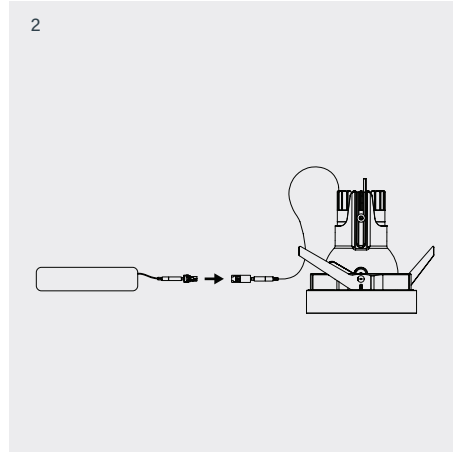

Installation

- 1 Cut 92mm diameter round aperture.
- 2 Plug driver into luminaire.
- 3-4 Fold back retention blades and insert luminaire into the aperture.

Maintenance

- 1 To access internal housing, remove facade by unscrewing anti-clockwise.
- 2 To remove the module housing, push back metal tabs using flathead screwdriver.
- 3 Twist the module housing, allowing it to drop out through tab slots.

Accent 100 Recessed Directional Type 2

100 10 0012 --,---

Power	14W
Voltage	240V-AC
Class	III
Ingress Protection	IP20
Cut-Out	Ø92 x 150mm Depth

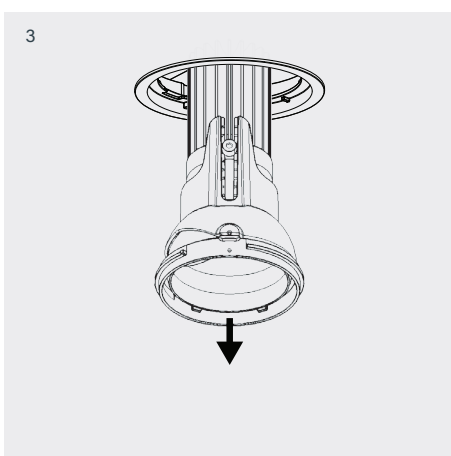
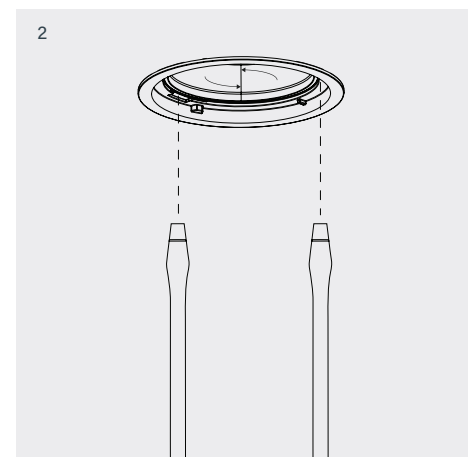
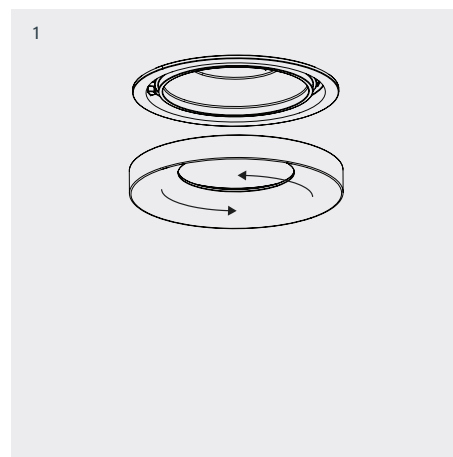
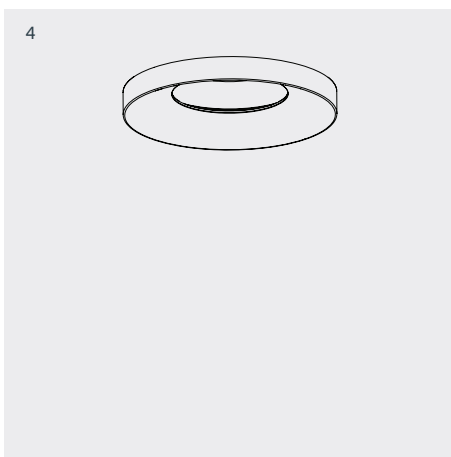
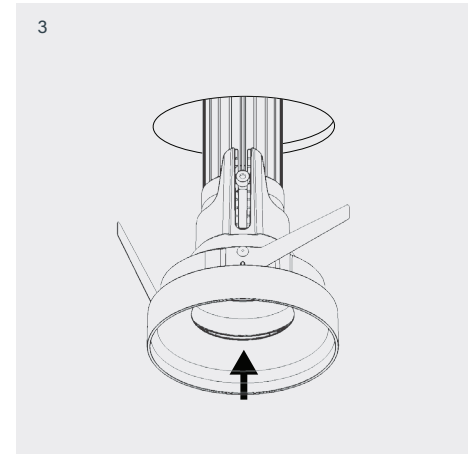
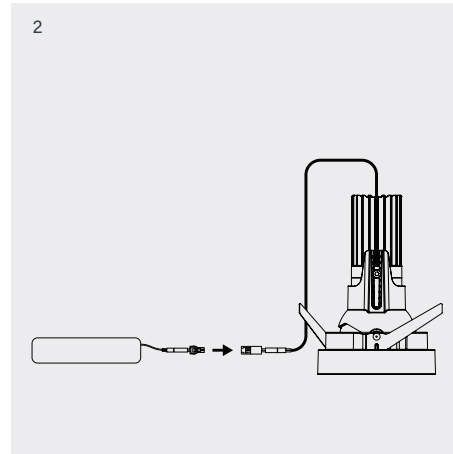
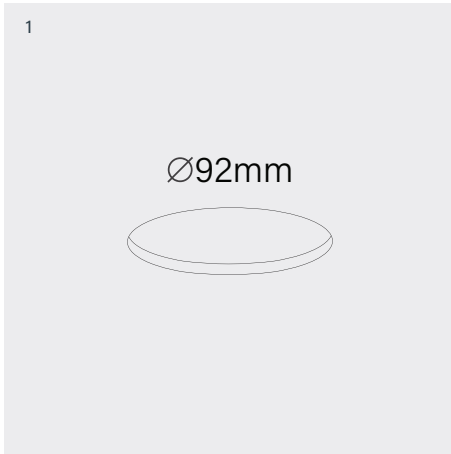

Installation

- 1 Cut 92mm diameter round aperture.
- 2 Plug driver into luminaire.
- 3-4 Fold back retention blades and insert luminaire into the aperture.

Maintenance

- 1 To access internal housing, remove facade by unscrewing anti-clockwise.
- 2 To remove the module housing, push back metal tabs using flathead screwdriver.
- 3 Twist the module housing, allowing it to drop out through tab slots.

Accent 100 Recessed Directional Type 3

100 10 0013 ---

Power	8W
Voltage	240V-AC
Class	III
Ingress Protection	IP20
Cut-Out	Ø92 x 92mm Depth

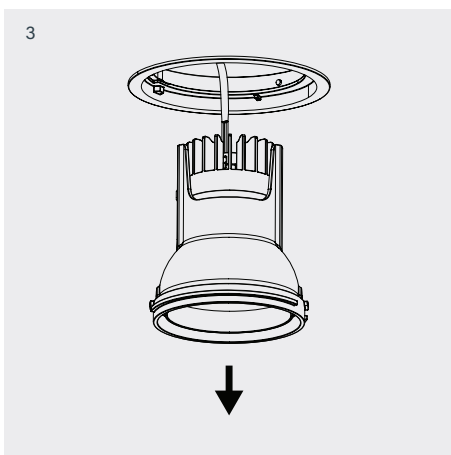
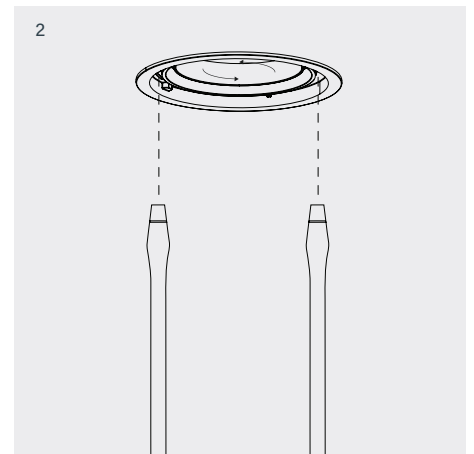
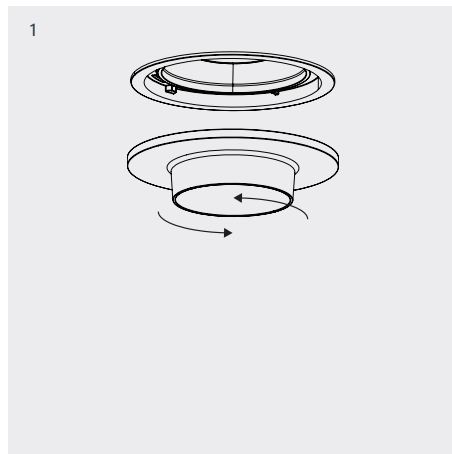
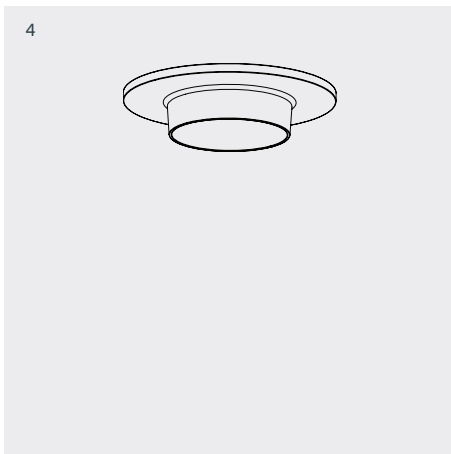
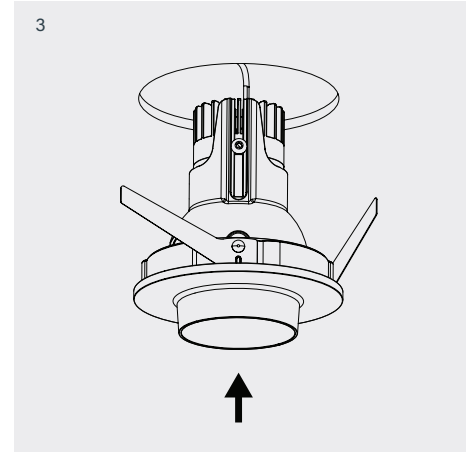
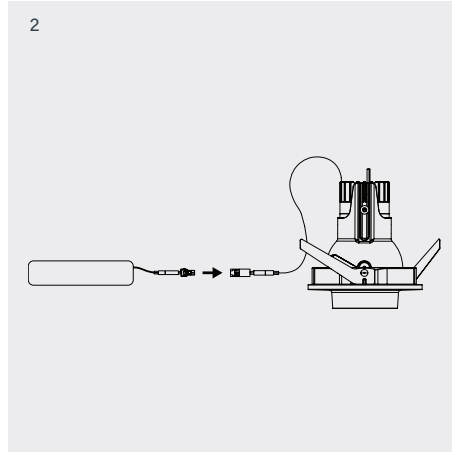

Installation

- 1 Cut 92mm diameter round aperture.
- 2 Plug driver into luminaire.
- 3-4 Fold back retention blades and insert luminaire into the aperture.

Maintenance

- 1 To access internal housing, remove facade by unscrewing anti-clockwise.
- 2 To remove the module housing, push back metal tabs using flathead screwdriver.
- 3 Twist the module housing, allowing it to drop out through tab slots.

Accent 100 Recessed Directional Type 3

100 10 0013 --,---

Power	14W
Voltage	240V-AC
Class	III
Ingress Protection	IP20
Cut-Out	Ø92 x 150mm Depth

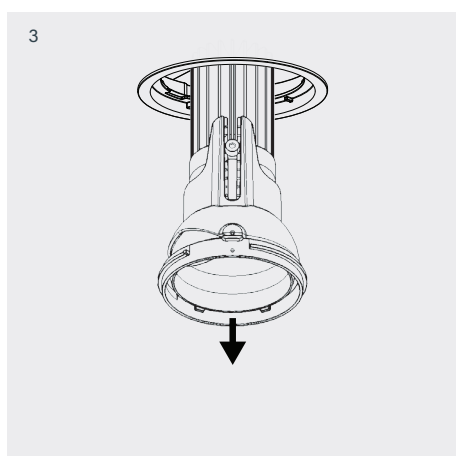
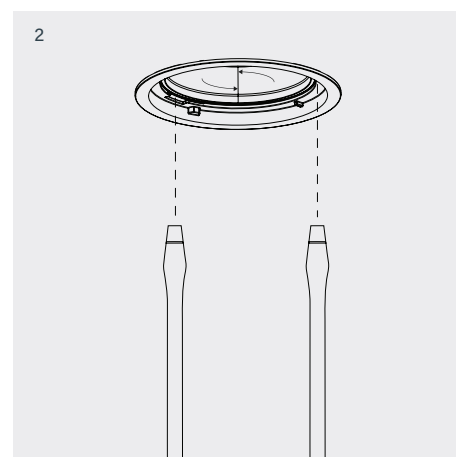
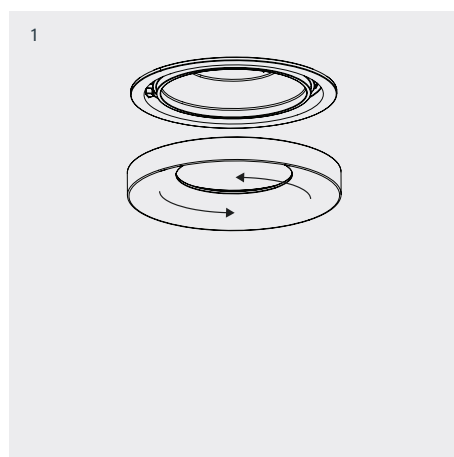
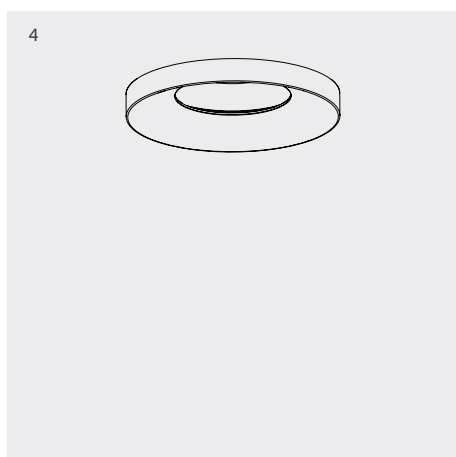
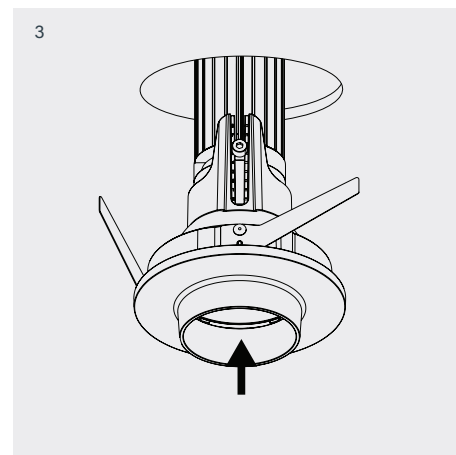
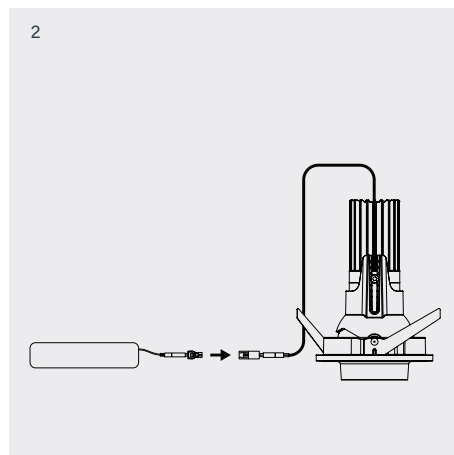
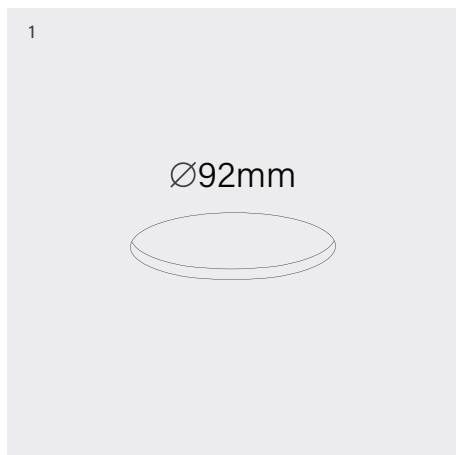

Installation

- 1 Cut 92mm diameter round aperture.
- 2 Plug driver into luminaire.
- 3-4 Fold back retention blades and insert luminaire into the aperture.

Maintenance

- 1 To access internal housing, remove facade by unscrewing anti-clockwise.
- 2 To remove the module housing, push back metal tabs using flathead screwdriver.
- 3 Twist the module housing, allowing it to drop out through tab slots.